

Study of P, PI and PID controller for speed control of induction motor

Chinmaya Ranjan Pradhan, Prativa Barik, Ipsita Pahi, Abhisek Gantayat

Department of Electrical and Electronics Engineering, NM Institute of Engineering and Technology, Bhubaneswar, Odisha

Department of Electrical and Electronics Engineering, Raajdhani Engineering College, Bhubaneswar, Odisha

Department of Electrical and Electronics Engineering, Aryan Institute of Engineering and Technology Bhubaneswar, Odisha

Department of Electrical and Electronics Engineering, Capital Engineering College, Bhubaneswar, Odisha

ABSTRACT —This paper has been attempted to presents the Comparative study of Proportional (P), Proportional Integral (PI), and Proportional Integral Derivative(PID) controller for speed control of induction motor. In general, the principle of operating a three phase IM indicates that the speed of the motor is directly related to the frequency of the supply. This fact has made the inverter fed induction motor having a very common configuration in the majority of industrial applications. The VSI-fed IM drives are increasingly applied in many recent industrial applications that require excellent transient performance of drives. Better performance of P, PI and PID controller is studied and compared.

I. INTRODUCTION

Everyone recognizes the vital role played by electrical motors in the development of industrial systems. Induction motors are today a standard for industrial electrical drives and high performance variable speed drive application have a series of advantages. There are several ways for speed control of IMs fed through the VSIs using different modulation techniques. Researchers, scientist and engineers are continuously inventing the new techniques and methods that cover the speed control requirements of the drive. Advanced control techniques such as fuzzy, neuro-fuzzy, genetic algorithm, sliding mode control, etc. have also been extensively used in motion control applications. Inherently straightforward operating characteristics, flexible performance and efficiency encouraged the use of VSI-fed induction motors in many types of industrial drive application. Most multi-purpose production machines benefit from adjustable speed control, since frequently their speeds must change to optimize the machine process or adapt it to various tasks for improved product quality, productionspeed.

VSIs are used to regulate the speed of three-phase squirrel cage IM (SCIM) by changing the frequency and voltage and consist of input rectifier, DC link and output converter. They are available for low voltage range and medium voltage range. The basic action involved in adjustable speed control of IM is to apply a variable voltage magnitude, and variable frequency to the motor so as to obtain variable speed operation. Both the VSI and Current Source Inverter (CSI) are used in adjustable speed AC drives.

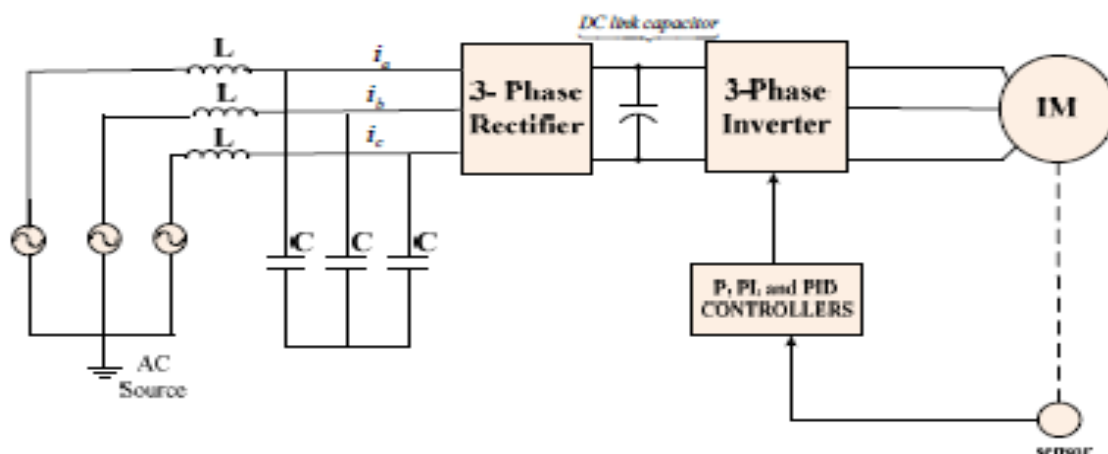

Fig.1 shows the block diagram of VSI-fed induction motor drive using P, PI and PID controller.

II. FUNDAMENTALS OF CONVENTIONAL CONTROLLERS SUCH AS P, PI AND PID CONTROLLER

PID controllers use a 3 basic behavior types of modes:

P-proportional, I- integral and D- derivative. While Proportional and integrative modes are also used as single control modes a derivative mode is rarely used on it's own in control systems. Such combinations such as PI and PID controller are very often in practical systems

(A) Proportional (P) Controller

A P controller system is a type of linear feedback control system. The P controller system is more complex than on-off control systems like a bi-metallic domestic thermostat, but simpler than a PID control system used in something like an automobile cruise control. In general it can be said that P controller cannot stabilize higher order processes.

For the 1st order processes, meaning the processes with one energy storage, a large increase in gain can be tolerated.

Proportional controller can stabilize only 1st order unstable process. Changing controller gain K can change closed loop dynamics. A large controller gain will result in control system with:

- Smaller steady state error, i.e. better reference following
- Faster dynamics, i.e. broader signal frequency band of the closed loop system and larger sensitivity with respect to measuring noise
- Smaller amplitude and phase margin

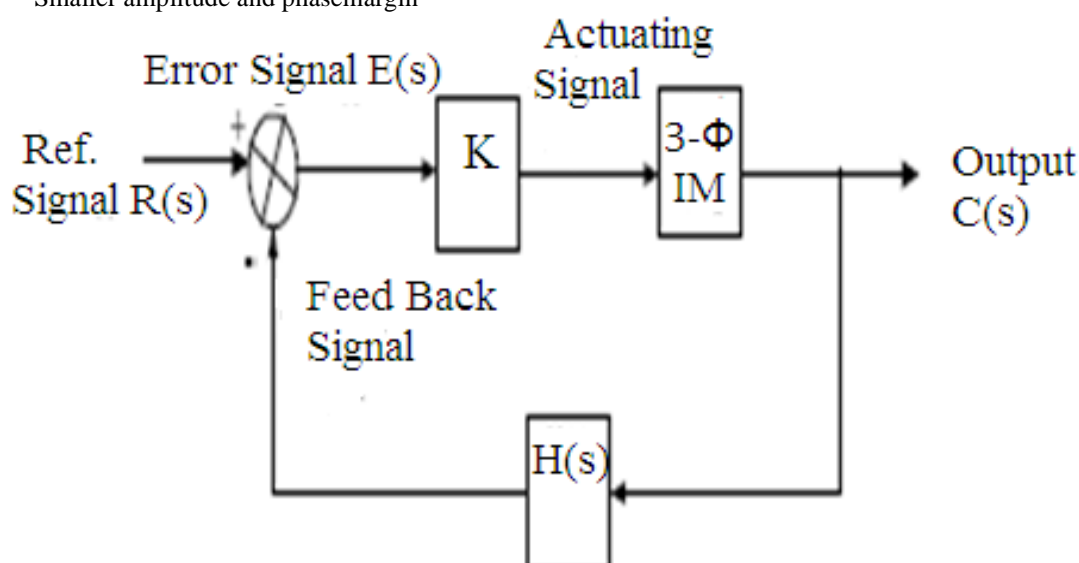

Fig.2. Block diagram of P controller

In the P controller algorithm, the controller output is proportional to the error signal, which is the difference between the set point and the process variable. In P controller the actuating signal for the control action in a control system is proportional to the error signal. The error signal being the difference between the reference input signal and feedback signal obtained from the output.

For the system considered as shown in the Fig. 5. The actuating signal is proportional to the error signal therefore; the system is called P controller system.

The error of signal given as follows:

$$e(t) = k[r(t) - h(t)]$$

It is desirable that the control system be under damped for the point of view of quick response. An under damped control system exhibits exponentially decaying in the output time response during the transient period.

(B) Proportional Integral (PI) Controller

At present, the PI controller is most widely adopted in industrial application due to its simple structure, easy to design and low cost. Despite these advantages, the PI controller fails when the controlled object is highly nonlinear and uncertain. PI controller will eliminate forced oscillations and steady state error resulting in operation of on-off controller and P controller respectively. However, introducing integral mode has a negative effect on speed of the response and overall stability of the system. Thus, PI controller will not increase the speed of response. It can be expected since PI controller does not have means to predict what will happen with the

error in near future. This problem can be solved by introducing derivative mode which has ability to predict what will happen with the error in near future and thus to decrease a reaction time of the controller. PI controllers are very often used in industry, especially when speed of the response is not an issue. A control without D mode is used when

1. Fast response of the system is not required
2. Large disturbances and noise are present during operation of the process
3. There is only one energy storage in process (capacitive or inductive)
4. There are large transport delays in the system.

Therefore, we would like to keep the advantages of the PI controller. This leads to propose a PI controller shown in Fig. 6.

This controller uses of the proportional term while the integral term is kept, unchanged.

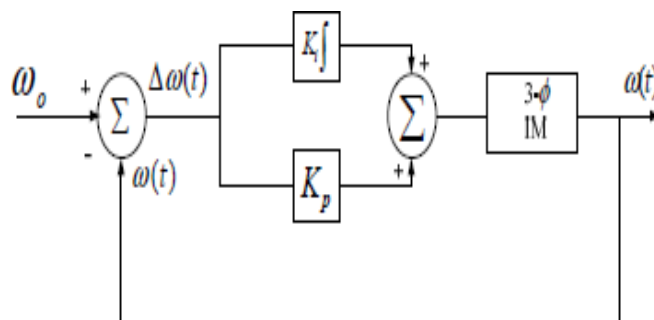

Fig.3. Block diagram of PI controller.

The controller output in this case is
 $u(t) = K_p \cdot e(t) + K_i \int e(t) dt$

Fig. 6. block diagram PI controller an integral error compensation scheme, the output response depends in some manner upon the integral of the actuating signal. This type of compensation is introduced by a using a controller which produces an output signal consisting of two terms, one proportional to the actuating signal and the other proportional to its integral. Such a controller is called proportional plus integral controller or PI controller.

(c) Proportional Integral Derivative (PID) Controller.

Many industrial controllers employ a proportional, integral plus differential PID regulator arrangement that can be tailored to optimize a particular control system. PID controller is most commonly used algorithm for controller design and it is most widely used controller in industry. The controllers used in industry are either PID controller or its improved version. The basic types of PID controller are parallel controller, serial controller, and mixed controller. The PID controller algorithm utilized for is design velocity algorithm, it is also called incremental algorithm. In the industry, PID controllers are the most common control methodology to use in real applications.

PID controller has all the necessary dynamics: fast reaction on change of the controller input (D mode), increase in control signal to lead error towards zero (I mode) and suitable action inside control error area to eliminate oscillations (P mode). Derivative mode improves stability of the system and enables increase in gain K and decrease in integral time constant T_i , which increases speed of the controller response. PID controllers are the most often used controllers in the process industry. The majority of control systems in the world are operated PID controllers. It has been reported that 98% of the control loops in the pulp and paper industries are controlled by single-input single output PI controllers and that in process control applications, more than 95% of the controllers are of the PID type controller. PID controller combines the advantage of proportional, derivative and integral control action.

Fig.4. Block diagram of PID controller.

$$u(t) = K_p e(t) + K_i \int e(t) dt + K_d \frac{de(t)}{dt}$$

The control signal is proportional to the error signal and the proportional gain K_p . A proportional controller will have the effect of reducing the rise time and will reduce, but never eliminate. If an integrator is added, the control signal is proportional to the integral of error and the integral gain K_i . Integral control will have the effect of reduced the error, in principle, to zero value. The in principle must be added, because there are always limits on accuracy in any system. Derivative control is used to anticipate the future behavior of the error signal by using corrective actions based on the rate of change in the error signal. The control signal is proportional to the derivative of the error and K_d is the derivative gain. Derivative control will have the effect of increasing the stability of the system, reducing the overshoot, and improving the transient response. Derivative control action can never be used alone because this control action is effective only during transient periods. The PID controller makes a control loop respond faster with less overshoot and most popular method of control by a great margin. The combined action has the advantages of each of the three individual control actions.

Table 1 Comparison Of Gain Response Of P, Pi And Pid Controllers.

Parameter	Speed of Response	Stability	Accuracy
increasing k	Increase	Deteriorates	Improves
increasing ki	Decrease	Deteriorates	Improves
increasing kd	Increase	Improves	No impact

Table 2 Effects On Various O/P Parameter Of P, Pi And Pid Controller W.R.T To Variation In Rise Time.

Parameter	P Controller	PI Controller	PID Controller
Rise time	Decrease	Decrease	Minor Decrease
Overshoot	Increase	Increase	Minor Decrease
Settling time	Small change	Increase	Minor Decrease
Steady state error	Decrease	Significant change	No change
Stability	Worse	Worse	If Kd Small Better.

Table 1 and 2 shows the effects of coefficients and effects of changing control parameters respectively. As we can there see is a decrease in rise time, overshoot and settling time and there is no change in steady state error PID Controller is better than P and PI controller.

III. PERFORMANCE COMPARISON OF P, PI, AND PID CONTROLLERS.

It is to be noted that, when gain is increasing speed of response is increasing in case of P and PID controller but in PI controller gain of response is decreasing. In PID controller there is a minor decrease or no changes are shown in various parameter which can see from table 1 and table 2. Hence there is no change in steady state error so PID controller is better than P and PID controller.

IV. CONCLUSION AND FUTURE SCOPE

P controller can stabilize only 1st order unstable process. PI controller can be used to avoid large disturbances and noise presents during operation process. Whereas PID controller can be used when dealing with higher order capacitive processes. The comparative study of P, PI and PID Controller is carried out, in which PID controller gives good response than any other controller. Further output response of VSI-Fed IM drive will be evaluated by using different controller i.e P, PI and PID controller. Based on different industrial application of induction motor, an appropriate controller can be chosen.

REFERENCES

- [1] Rajneesh Mishra, S. P. Singh, Deependra Singh, B. Singh, and Dinesh Kumar, "Investigation of Transient Performance of VSI-Fed IM Drives using Volts/Hz and Vector Control Techniques". IEEE International Conference on Power, Control and Embedded Systems, vol. 20, no. 2, April 2012.
- [2] Vijay Babu Koreboina, Shankar J Magajikondi, and A.B. Raju, "Modeling, Simulation and PC Based Implementation of a Closed Loop Speed Control of VSI- Fed Induction Motor Drive," IEEE Conference 2011.
- [3] Baburaj Karanayil, Muhammed Fazlur Rahman, and Colin Grantham, "Online Stator and Rotor Resistance Estimation Scheme Using Artificial Neural Networks for Vector Controlled Speed Sensor less Induction Motor Drive," IEEE Transaction on Industrial Electrical, vol. 54, no. 1, Feb 2007.
- [4] Yongxian Song, Juanli Ma, Hanxia Zhang and Naiba He, "Digital Implementation of Neural Network Inverse Control for Induction Motor Based on DSP," IEEE International Conference, vol. 1, 2010.
- [5] J. Klima "Time and frequency domain analysis of fault- tolerant space vector PWM VSI- Fed induction

- motor drive,” IEEE Transactions on Power Electronics, vol. 152, no. 4, July2005.
- [6] Guillermo J. Silva, AniruddhaDatta, and S. P. Bhattacharyya, “New Results on the Synthesis of PID Controllers,” IEEE Transaction on Automatic Control, vol. 47, no. 2 February2002.
- [7] CiroAttaianese, Vito Nardi and Giuseppe Tomasso, “A Self-Commissioning Algorithm for VSI-Fed Induction Motors,” IEEE Transactions on Power Electronics, vol.17, no. 6, November2002.
- [8] Scott Wade, Matthew W. Dunnigan, and Barry W. Williams, “Modeling and Simulation Of Induction Machine Vector Control with Rotor Resistance Identification,”IEEE Transactions on Power Electronics, vol. 12, no. 3, may1997.
- [9] SangshinKwakand Hamid A. Toliyat “A Hybrid Converter System for High Performance Large Induction Motor Drives,” IEEE Transactions On Energy Conversion, vol. 20, no. 3, September 2005.
- [10] DrazenDujic and Martin Jones, “Analysis of Output Current Ripple rms in Multiphase Drives Using Space Vector Approach,” IEEE Transactions on PowerElectronics, vol. 24, no. 8, August2009.
- [11] Desh Deepak Gautam and V. K. Giri, “Simulation and Comparison of SPWM and SVPWM FED Three Phase Induction Motor,” IJBSTR Research Paper, Vol. 1, JULY 2013.
- [12] El Zoghby, H.M, Sharaf, S.M, Ghazy, M.A, “Control of Two Phase Induction Motor By Changing The Phase Difference Angle,” ,” IEEE Conference Publication , vol.1, no.1,2006.
- [13] H. S. Rajamani and R. A. McMahon, “Induction Motor drives for domestic appliances,” IEEE Transactions on Industrial Applications, vol. 3, No. 3, pp. 21-26, 1997
- [14] Do-Hyun Jang, “Volt, Frequency and Phase Difference Angle Control Inverter Fed Two Phase of Induction Motor,”IEEE Transactions on PowerElectronics, vol. 9, no. 4, July1994.
- [15] Won Sang Kim, KyoBeum Lee, Sunghoi Huh, Blaabjerg, F, “Robust Sensorless Control for Induction Motor Drives Fed By a Matrix Converter With Variable Structure Model RefernceAdaptive,”IEEE Conference on Power Electronics, June2007.
- [16] Inazume, Ohisihi, K, Haya H, “High Power Factor Control of Inverter o/p Power of IPM Motor Driven By Inverter System without Eltrolytic Capacitor,” IEEE Transactions Symposium on Industrial Electronics, vol.1, June2011.